



Profit from the Eagle Advantage®

Specification Sheet

Short Form Specifications

Eagle RedHots® Single-Tank Electric Fryer, model _____. All heavy gauge stainless steel construction. Stainless steel deep-drawn 10" x 14" fry tank is removable for cleaning or filtering. Snap action thermostat with indicator light, hi-limit safety control with reset button and indicator light. Two 4" x 11" nickel-plated fry baskets. Cast metal legs with flanged feet. 15-lb. fat capacity. Single-phase 60-cycle electricity. Available in 120 volts/15 amps; 208 volts/19.8 amps; or 240 volts/22.9 amps.

Eagle RedHots® Double-Tank Electric Fryer, model _____. All heavy gauge stainless steel construction. Stainless steel deep-drawn 10" x 14" fry tanks are removable for cleaning or filtering. Snap action thermostat with indicator light, hi-limit safety control with reset button and indicator light. Two 4" x 11" nickel-plated fry baskets per tank. Cast metal legs with flanged feet. 30-lb. fat capacity. Single-phase 60-cycle electricity. Available in 208 volts/39.6 amps or 240 volts/45.8 amps.

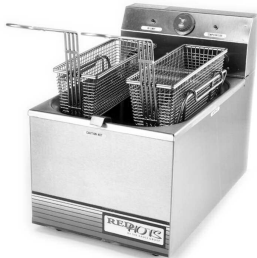

single tank model

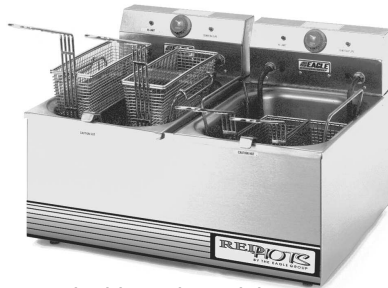

double tank model

Options / Accessories

- Double fry basket
- 2½" high legs
- Night cover

EAGLE GROUP

100 Industrial Boulevard, Clayton, DE 19938-8903 USA
Phone: 302-653-3000 • Fax: 302-653-2065
www.eaglegrp.com

Foodservice Division: Phone 800-441-8440

MHC/Retail Display Divisions: Phone 800-637-5100

For custom configuration or fabrication needs, contact our SpecFAB® Division.

Phone: 302-653-3000 • Fax: 302-653-3091 • e-mail: specfab@eaglegrp.com

Item No.:	_____
Project No.:	_____
S.I.S. No.:	_____

RedHots® Electric Fryers

MODELS:

- | | | |
|------------------------------------|---------------------------------|---------------------------------|
| <input type="checkbox"/> EF10-120 | <input type="checkbox"/> 307543 | <input type="checkbox"/> 309781 |
| <input type="checkbox"/> EF10-240 | <input type="checkbox"/> 307546 | <input type="checkbox"/> 340859 |
| <input type="checkbox"/> EF102-240 | <input type="checkbox"/> 309197 | |

Fry tank

- All-stainless steel deep-drawn one-piece construction.
- 10" x 14" (254 x 356mm).
- Removable for easy cleaning or filtering of fat.
- Available are single-tank units with 15-lb. fat capacity, and double-tank unit with 30-lb. capacity.

Thermostat

- Robertshaw snap action complete with indicator light provides for accurate temperature control.

Hi limit safety control

- Provides total system shutdown in case of malfunction.
- Complete with reset button and indicator light.

Heating elements

- Self-cleaning Incoloy® sheath for long life and high performance.

Fry baskets

- 4" x 11" (102 x 279mm) each.
- Heavy plated mesh construction.
- Two provided with single-tank models, four provided with double-tank model.
- Optional double fry baskets available.

Design and Construction Features

- Highly polished stainless steel body.
- Line cord and plug furnished on single tank models.
- Designed for direct field wiring on double tank models.

Certifications / Approvals



New York M.E.A. No. 449-84-E





Profit from the Eagle Advantage®

Item No.: _____
 Project No.: _____
 S.I.S. No.: _____

RedHots® Electric Fryers

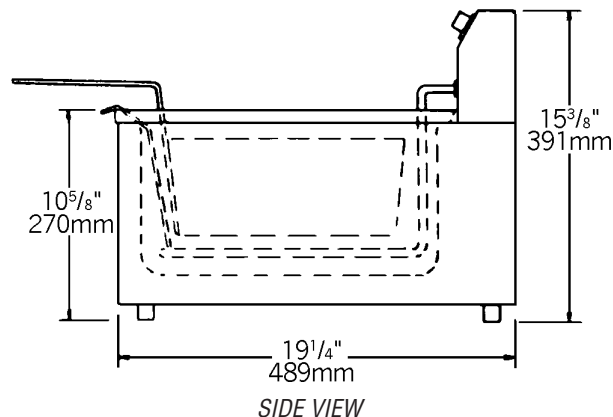

Single-Tank Electric Fryers

model #	electrical data **	performance *** – french fries, raw-to-finish	width		depth		height *	weight lbs. kg	—tank size—			fat capacity				
			in.	mm	in.	mm			in.	mm	in.	mm	lbs.	kg		
EF10-120	120V, 15A, 1800W	120V: 6 lbs.(2.7 kg)/hr	12"	305	19 1/4"	489	10 5/8"	270	31	14.1	10"	254	14"	356	15	6.8
EF10-240 ****	208V, 19.8A, 4200W 240V, 22.9A, 5500W	208V: 20 lbs. (9.1 kg)/hr 240V: 30 lbs. (13.6 kg)/hr	12"	305	19 1/4"	489	10 5/8"	270	31	14.1	10"	254	14"	356	15	6.8

Double-Tank Electric Fryer

model #	electrical data **	performance *** – french fries, raw-to-finish	width		depth		height *	weight lbs. kg	—tank size—			fat capacity				
			in.	mm	in.	mm			in.	mm	in.	mm	lbs.	kg		
EF102-240 ****	208V, 39.6A, 8400W 240V, 45.8A, 11000W	208V: 40 lbs. (18.1 kg)/hr 240V: 60 lbs. (27.2 kg)/hr	25"	635	19 1/4"	489	10 5/8"	270	61	27.7	10"	254	14"	356	30	13.6

* Optional 2 1/2" (64mm) legs available – part #309197.

** Based on single-phase, 60-cycle electricity.

*** Double the performance for precooked convenience foods. Preheat to 350°F for 4 1/2 minutes. Fryer performance is limited by the maximum available voltage in line.

**** 240-volt models can be used for 208V or 240V operation.

Accessories/Replacements for Electric Fryers

model #	description
307543	replacement basket, left side, for single-tank fryers only
307546	replacement basket, right side, for single-tank fryers only
309197	2 1/2" (57mm)-high legs, set of four
309781	double-fry basket, 8 1/4" x 9 1/4" x 4" (210 x 235 x 102mm)
340859	divider for double-tank fryer
361673	night cover



#309781
double-fry basket

EAGLE GROUP

100 Industrial Boulevard, Clayton, DE 19938-8903 USA

Phone: 302-653-3000 • Fax: 302-653-2065

www.eaglegrp.com

Foodservice Division: Phone 800-441-8440

MHC/Retail Display Divisions: Phone 800-637-5100

Printed in U.S.A.
©2008 by Eagle Group

Rev. 09/08

Spec sheets available for viewing, printing or downloading from our online literature library at www.eaglegrp.com

Although every attempt has been made to ensure the accuracy of the information provided, we cannot be held responsible for typographical or printing errors. Information and specifications are subject to change without notice. Please confirm at time of order.