



Profit from the Eagle Advantage®

Specification Sheet

Short Form Specifications

Eagle Hot Food Tables, open base design, model _____ . Top and body to be heavy gauge type 430 stainless steel. Beaded top openings to be 12 3/32" x 20 3/32". Heating compartments to be 8" deep, galvanized, and insulated on all four sides and bottom with 1" fiberglass or equal. Each compartment to have individual high-output jet burner rated at 3,500 BTU each. Each burner controlled by a high-medium-low adjustable gas valve with adjustable pilot light. Removable galvanized steel radiation plate provided in each compartment, and gas pressure regulator provided. Polycarbonate cutting board, 8" wide, provided. Legs to be 1 1/2" O.D. tubing, with adjustable undershelf and adjustable non-marking plastic feet.



#HT3-NG hot food table shown with optional Flex-Master® overshelves*

Options / Accessories

- Hardwood cutting board
- Spillage pans
- Rolltop cover
- Food pan/insets
- Overshelves
- Bolted-in undershelf
- Top adapters

* See Catalog Sheet #EG30.18 for more information on Flex-Master® overshelves

EAGLE GROUP

100 Industrial Boulevard, Clayton, DE 19938-8903 USA

Phone: 302-653-3000 • Fax: 302-653-2065

www.eaglegrp.com

Foodservice Division: Phone 800-441-8440

MHC/Retail Display Divisions: Phone 800-637-5100

For custom configuration or fabrication needs, contact our SpecFAB Division.

Phone: 302-653-3000 • Fax: 302-653-3091 • e-mail: specfab@eaglegrp.com

Item No.: _____
 Project No.: _____
 S.I.S. No.: _____

Gas Hot Food Tables— Open Base, Stationary

MODELS:

- | | | | |
|---------------------------------|---------------------------------|----------------------------------|----------------------------------|
| <input type="checkbox"/> HT2-NG | <input type="checkbox"/> HT4-NG | <input type="checkbox"/> SHT2-NG | <input type="checkbox"/> SHT4-NG |
| <input type="checkbox"/> HT2-LP | <input type="checkbox"/> HT4-LP | <input type="checkbox"/> SHT2-LP | <input type="checkbox"/> SHT4-LP |
| <input type="checkbox"/> HT3-NG | <input type="checkbox"/> HT5-LP | <input type="checkbox"/> SHT3-NG | <input type="checkbox"/> SHT5-LP |
| <input type="checkbox"/> HT3-LP | <input type="checkbox"/> HT5-NG | <input type="checkbox"/> SHT3-LP | <input type="checkbox"/> SHT5-NG |

Construction

- Table body and top are constructed of highly polished 22 gauge 430 series stainless steel.
- Top features die-stamped beaded openings measuring 12 3/32" x 20 3/32" (307 x 510mm).
- A poly cutting board, 8" (203mm) wide and 1/2" (13mm) thick, is mounted on stainless steel brackets located on control side of unit.
- Legs are 1 1/2" (41mm) O.D. tubing fitted with non-marking plastic feet.
- Units with galvanized or stainless steel undershelf available.
- All models are 30 1/2" (774mm) wide and 34" (863mm) high.

Heat compartments

- Under each top opening is a heat compartment with a die-stamped 8" (203mm) deep, heavy gauge galvanized liner.
- Each compartment is insulated on all four sides and bottom with 1" (25mm) thick fiberglass or equal, having a thermal conductivity of 0.27 or less.

Gas heat units

- Each compartment features an individual burner rated at 3,500 BTU designed for use with natural gas or propane gas as specified.
- Each burner is controlled by a High-Medium-Low adjustable gas valve with adjustable pilot light.
- A removable galvanized steel radiation plate is also provided in each compartment and a gas pressure regulator is furnished with all units.

Certifications / Approvals



New York MEA 375-84-E





Profit from the Eagle Advantage®

Item No.: _____
 Project No.: _____
 S.I.S. No.: _____

Gas Hot Food Tables—Open Base, Stationary

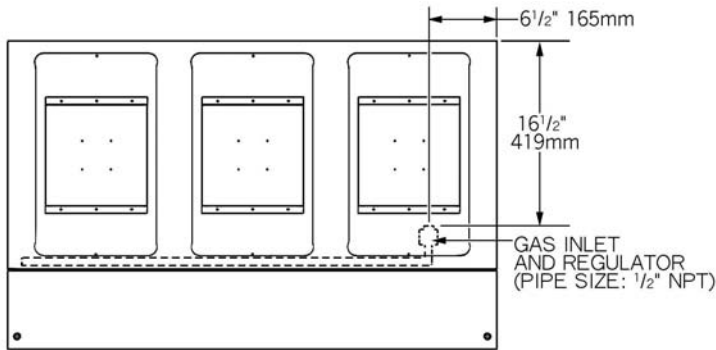

TOP VIEW

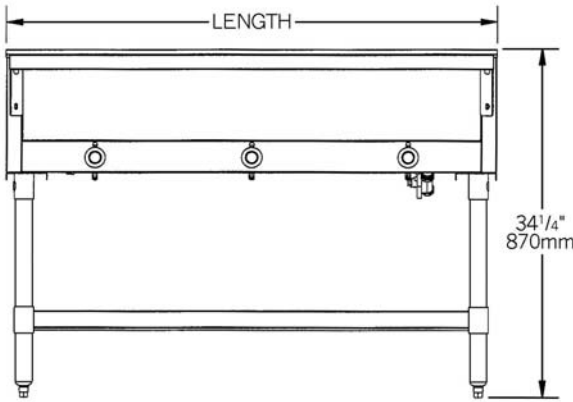

FRONT VIEW

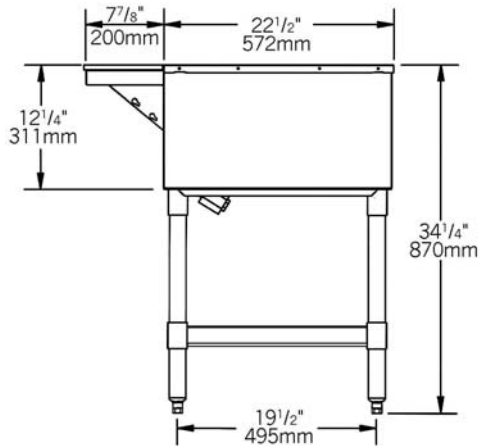

SIDE VIEW

WITH GALVANIZED LEGS & UNDERSHELF model #	WITH STAINLESS STEEL LEGS & UNDERSHELF model #	type of gas	# of openings	total BTU rating	length in. mm	weight lbs. kg
HT2-NG	SHT2-NG	natural gas	2	7,000	33" 838	97 44.0
HT2-LP	SHT2-LP	liquid propane	2	7,000	33" 838	97 44.0
HT3-NG	SHT3-NG	natural gas	3	10,500	48" 1219	125 56.7
HT3-LP	SHT3-LP	liquid propane	3	10,500	48" 1219	125 56.7
HT4-NG	SHT4-NG	natural gas	4	14,000	63 1/2" 1613	158 71.7
HT4-LP	SHT4-LP	liquid propane	4	14,000	63 1/2" 1613	158 71.7
HT5-NG	SHT5-NG	natural gas	5	17,500	79" 2007	193 87.5
HT5-LP	SHT5-LP	liquid propane	5	17,500	79" 2007	193 87.5

EAGLE GROUP
 100 Industrial Boulevard, Clayton, DE 19938-8903 USA
 Phone: 302-653-3000 • Fax: 302-653-2065
 www.eaglegrp.com

Foodservice Division: Phone 800-441-8440
 MHC/Retail Display Divisions: Phone 800-637-5100

Printed in U.S.A.
 ©2008 by Eagle Group

Rev. 08/08

Spec sheets available for viewing, printing or downloading from our online literature library at www.eaglegrp.com

Although every attempt has been made to ensure the accuracy of the information provided, we cannot be held responsible for typographical or printing errors. Information and specifications are subject to change without notice. Please confirm at time of order.