



# Master Series Heavy Duty Griddle Top Range

Item: \_\_\_\_\_  
 Quantity: \_\_\_\_\_  
 Project: \_\_\_\_\_  
 Approval: \_\_\_\_\_  
 Date: \_\_\_\_\_

Master Series Heavy Duty Griddle Top Range

Models:

- M47R       M47S       M47T

Valve Controlled Griddle Top Range



Model M47R

### Standard Features:

- Stainless steel front; black powder coat epoxy sides
- 6" (152mm) chrome steel adj. legs
- 7-1/2" (191mm) stainless steel front rail
- 1" (25mm) thick steel griddle plate
- 2-5/16" (591mm) high welded steel splash guard, sides and back
- Clip-on stainless steel backsplash
- Removable front-mounted stainless steel grease receptacle
- Hi-Lo valve control for each griddle burner
- Three "H" griddle burners 99,000 BTU (29 kW) total
- Piezo spark ignition for oven
- Fully porcelainized oven interior
- Storage base interior of aluminized steel w/shelf, (Suffix S)
- Modular top section, (Suffix T)
- 40,000 BTU (11.72kW) natural gas, 35,000 (10.25 kW) propane gas cast iron oven burner

### Optional Features:

- Stainless steel common front rail up to 68" (1728mm) wide (two or more units in a battery)

- Stainless steel main back, left, right or both sides
- Fully grooved griddle (or grooved sections)
- Stainless steel oven interior
- Convection oven base, add C to Model No., e.g. M47RC
- Additional oven rack
- Rear gas connection, 3/4" or 1" NPT
- Gas regulator 3/4" or 1-1/4"
- Gas shut off valve; 3/4", 1" or 1-1/4" NPT
- Gas flex hose & quick disconnect (3/4", 1" or 1-1/4" NPT x 5') w/restraining device, please specify
- End caps and cover, (NC) - specify
- Swivel casters (4) w/front brakes
- Polyurethane non-marking swivel casters (4) w/front brakes
- 6" (152mm) stainless steel adj. legs
- Dais base (not for use with "RC" oven)
- Storage base shelf of aluminized or stainless steel
- Stainless steel tubular high shelf, single or double deck
- Stainless steel backguard: 10" (354mm), 17" (432mm) or 33" (838mm)
- 230 volt, 50 cycle components, RC motor (export)
- Celsius dial for oven thermostat, NC

### Specifications:

Heavy-duty gas range with oven, Model M47R. One 34" (864mm) wide, valve-controlled griddle. 1" (25mm) thick, 99,000 BTU (29 kW) total. 34" (864mm) wide x 38" (965mm) deep, including 7-1/2" (191mm) deep stainless steel front rail. Porcelain enamel oven interior measuring 26-1/4" (667mm) wide x 13-1/2" (343mm) high x 29" (737mm) deep. 40,000 BTU (11.72 kW) cast iron burner. Stainless steel front with black powder coat epoxy sides. 139,000 BTU (40.73 kW) total. Natural or propane gas. Also Available with storage base(s) w/doors, suffix S, and Modular top, suffix T.



NOTE: Ranges supplied with casters must be installed with an approved restraining device.

Garland Commercial Industries, LLC  
 185 East South Street  
 Freeland, PA 18224  
 Phone: (570) 636-1000  
 Fax: (570) 636-3903

Garland Commercial Ranges Ltd  
 1177 Kamato Road,  
 Mississauga, Ontario  
 L4W 1X4 CANADA  
 Phone: 905-624-0260  
 Fax: 905-624-5669



Product	Width: In(mm)	Depth: In(mm)	Height: In(mm) (w/ NSF Legs)	Height: In(mm) (w/o NSF Legs)	Oven/Storage Base Interior: in(mm)		
					Width	Depth	Height
<b>M47R</b>	34(864)	38(965)	36-3/8(924)	30-3/8(772)	26-1/4(667)	29(737)**	13-1/2(343)
<b>M47S</b>	34(864)	38(965)	36-3/8(924)	36-3/8(924)	26(665)	30-1/2(773)	20-1/2(519)
<b>M47T</b>	34(864)	38(965)	36-3/8(924) w/stand	9-1/2 (241) w/o stand*	N/A	N/A	N/A

\*Modular top has 1-1/2" seating flanges. \*\*RC oven is 25" (635mm) deep.

INPUT-BTU/hr (Natural Gas)	M47R & M47RC	M47S & M47T
<b>Top Section</b>	99,000 (29.00kW)	99,000 (29.00kW)
<b>Oven***</b>	40,000 (11.72kW)	N/A
<b>TOTAL</b>	139,000 (40.72kW)	99,000 (29.00kW)

RC=Range w/Convection Oven R=Range w/Oven S=Range w/Storage Base T=Modular Top  
 \*\*\* Oven rated 35,000BTU (10.25kW) for Propane Gas

INSTALLATION NOTES			Shipping Wt: (Lb/Kg) <sup>2</sup>
Combustible Wall Clearances <sup>1</sup>	Entry Clearances	Operating Pressure	
Sides: 14" (356mm) Back: 6" (152mm)	Crated: 39-1/4" (997mm) Uncrated: 34-1/4" (870mm)	Natural: 6" WC (15mbar) Propane: 10" WC (25mbar)	M47R 600/273 M47S 500/227 M47T 410/186

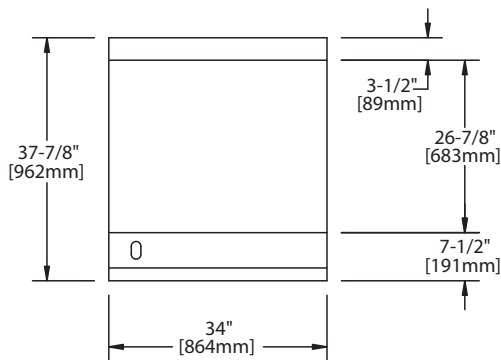

<sup>1</sup>NOTE: Installation clearance reductions are applicable only where local codes permit.

<sup>2</sup>Shipping Cubic Feet 50 for R & S Models, 20 for T models

Data applies only to North America

Gas input ratings shown here are for installations up to 2,000 ft. (610m) above sea level. Specify altitudes over 2,000 ft.

Electrical characteristics each RC oven: 1/3 HP motor, 120 VAC, single phase, 3.4 amps, 6 ft. (1.8m) power cord with NEMA 5-15P plug provided. 230 VAC export is direct connect, single phase, 50 Hz.

Please specify gas type when ordering.

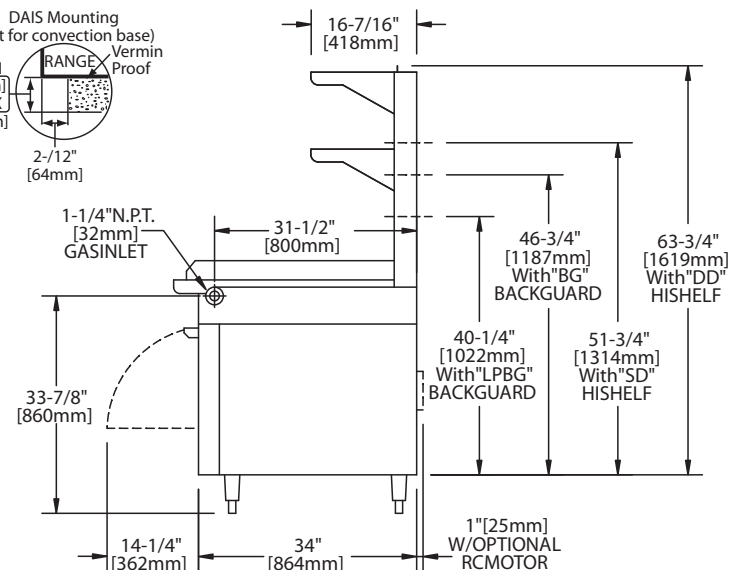
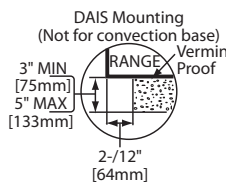
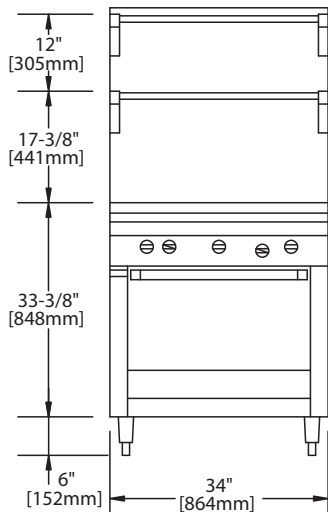

Form# M47 (09/02/09)