

Pressure Fryers

PFE-500 Electric pressure fryer
PFE-500 with Computron 8000™ control module

Pressure fryers use controlled low pressure for faster cooking at lower temperatures. This method seals in the food's moisture and natural juices while sealing out excess shortening for healthier, better-tasting, hot fresh food.

Description

Henny Penny pressure fryers represent one of the most profitable, efficient and space-saving methods of high-volume cooking.

- The PFE-500 cooks up to 14 lbs. (6.3 kg) of food per load from five square feet of floor space.
- Choose Computron 8000™ control option for programmable operation.
- Built-in filtration system extends shortening life at optimal levels.

Optional Computron 8000™ control

- Large 16-character digital display with multiple language settings.
- Automatic or manual idle, melt cycles.
- 10 programmable cook cycles.
- Automatic load compensation.
- Programmable on/off pressure.
- Optional filter enforcement.
- Temperature display in °F or °C.
- Cook Cycle Usage Summary.
- Programmable user password.
- Daily statistics for past 7 days.
- Monitors amps supplied to heating elements.

Main Features

- Standard electro-mechanical control with easy to use temperature and timer controls.
- Stainless steel rectangular fry pot promotes more even cooking.
- Built-in filtration system.



Above: Computron 8000™ control

Right: PFE-500 pressure fryer with standard control



- Cast aluminum alloy lid.
- Heavy-duty lid hinge, spring and front lid latch.
- Color keyed locking spindle engages pressure seal.
- Patented design keeps lid locked until pressure drops to 1 psi.
- Automatic pressure release valve.
- Baffled exhaust stack.
- Channel underneath lid directs condensation away from hot shortening when lid is raised.
- Raised edge on fryer top catches spills.
- Cook cycle completion signal.

Accessories shipped with unit:

Choice of start-up filter media:

- (6) SUPERSORB® filter pads OR
- (5) Carbon pad filter envelopes OR
- (5) Non-woven carbon filter envelopes OR
- (5) PHT filter envelopes

- (1) Set of cleaning brushes
- (1) Tube of molycolite lube
- (1) Installation and operating manual

Options available separately:

- Heavy duty casters (2 locking)
- Filter pan dolly
- Rinse hose attachment
- Full size basket and handle
- 4-tier stainless steel basket and handle

Henny Penny Corporation
P.O. Box 60
Eaton, OH 45320

+1 937 456.8400
+1 937 456.8434 Fax

Toll free in USA
800 417.8417
800 417.8434 Fax

www.hennypenny.com

PFE-500 Specifications

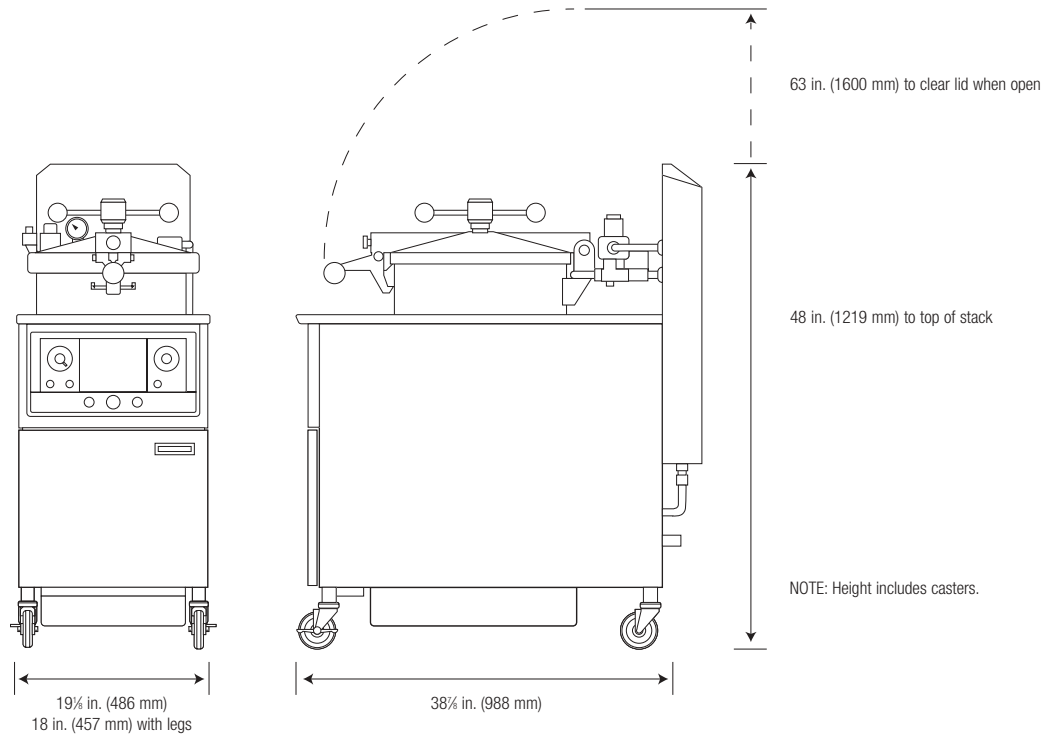

Dimensions

Clearances

Floor Space

Capacity

Product
Shortening

Heating Format

Pressure

Shipping Weight

Shipping Cube Dimensions

Listings

Electrical

Sides and back: 6 in. (152 mm)

5 sq.ft. (.46 m²)

14 lbs. (6.3 kg)
48 lbs. (21.7 kg)

Electric immersion: three heating elements, 3750W each (11.25 kW total) or 4500W each (13.5 kW total)

Operating pressure: 12 psi. Safety valve setting: 14.5 psi.

325 lbs. (147 kg)

L x W x H: 44½ x 21¾ x 56 in. (1.13 x 0.55 x 1.42 m)

UL, CUL, UL Sanitation, CE

Voltage	Phase	Cycle/Hz	Amps		Wire
			11250W	13500W	
190-208	1	50 or 60	54.0	65.0	2+G
190-208	3	50 or 60	32.0	38.0	3+G
208	1	60	54.0	65.0	2+G
208	3	60	32.0	38.0	3+G
220-240	1	50 or 60	52.0	58.0	2+G
220-240	3	50 or 60	30.0	33.0	3+G
220/380	3	50 or 60	17.1	20.5	4+G
240/415	3	50 or 60	18.6	18.8	4+G
380-415	3	50	17.1	18.8	3NG
480	3	60	14.0	16.0	3+G

Optional power cord and plug can be supplied for 3 phase 208V and 220-240V units, only.

Plug type:
NEMA 15-50P



Specifications subject to change without notice.
For up-to-date product information, please visit
www.hennypenny.com.

Order from:

Manufactured by:

Henny Penny Corporation

P.O. Box 60
Eaton, OH 45320