

Pressure Fryers

PFG-600 Gas pressure fryer
PFG-600 with Computron™ 8000 control module

Pressure fryers use controlled low pressure for faster cooking at lower temperatures. This method seals in the food's moisture and natural juices while sealing out excess shortening for healthier, better-tasting, hot fresh food.

Description

Henny Penny pressure fryers represent one of the most profitable, efficient and space-saving methods of high-volume cooking.

- The PFG-600 cooks up to 12.5 lbs. (5.7 kg) of food per load from five square feet of floor space.
- Choose Computron™ 8000 control option for programmable operation.
- Built-in filtration system extends shortening life at optimal levels.

Optional Computron™ 8000 Control

- Large 16-character digital display with multiple language settings.
- Automatic or manual idle, melt cycles.
- 10 programmable cook cycles.
- Automatic load compensation.
- Programmable on/off pressure.
- Optional filter enforcement.
- Temperature display in °F or °C.
- Cook Cycle Usage Summary.
- Programmable user password.
- Daily statistics for past 7 days.

Main Features

- Standard electro-mechanical control with easy to use temperature and timer controls.
- Stainless steel rectangular fry pot promotes more even cooking.
- Built-in filtration system.
- Cast aluminum alloy lid.



*Above: Computron™ 8000 control.
Right: PFG-600 gas pressure fryer with electro-mechanical control*



- Heavy-duty lid hinge, spring and front lid latch.
- Color keyed locking spindle engages pressure seal.
- Patented design keeps lid locked until pressure drops to 1 psi.
- Automatic pressure release valve.
- Baffled exhaust stack.
- Channel underneath lid directs condensation away from hot shortening when lid is raised.
- Raised edge on fryer top catches spills.
- Cook cycle completion signal.

Accessories shipped with unit:

Choice of start-up filter media:

- (2) SUPERSORB® filter pads OR
- (2) Carbon pad filter envelopes OR
- (2) Non-woven carbon filter envelopes OR
- (2) PHT filter envelopes

Options available separately:

- Heavy duty casters (2 locking)
- Filter pan dolly
- Rinse hose attachment
- Full size basket and handle
- 3-tier stainless steel basket and handle

Henny Penny Corporation
PO Box 60
Eaton OH 45320 USA

+1 937 456.8400
+1 937 456.8434 Fax

Toll free in USA
800 417.8417
800 417.8434 Fax

www.hennypenny.com

PFG 600 Specifications

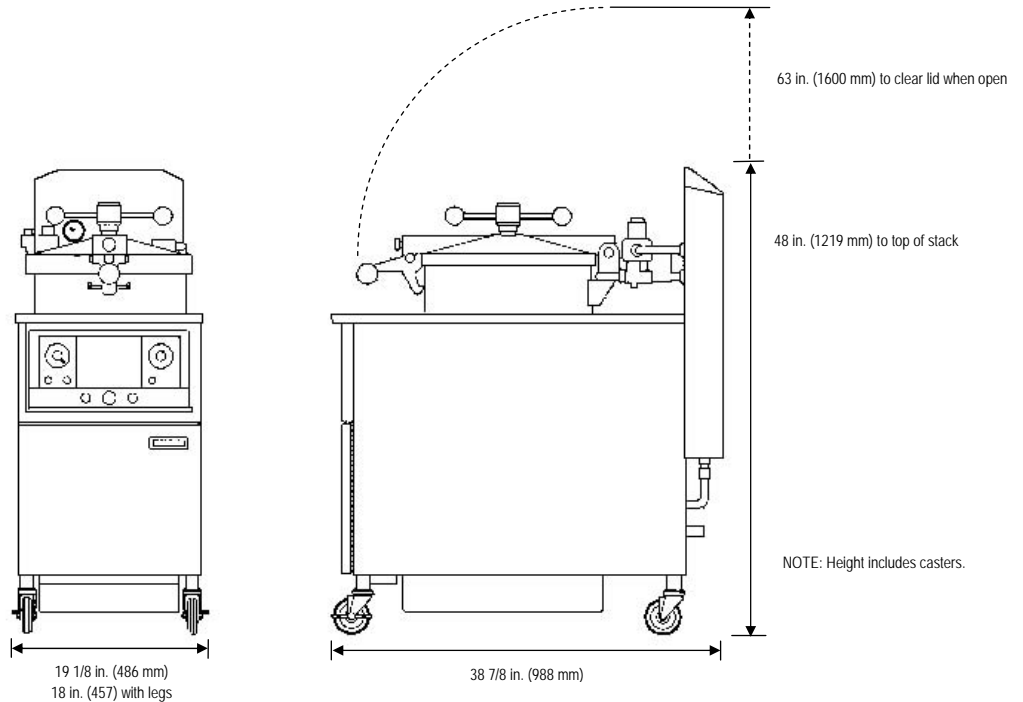

Dimensions

Clearances

Floor Space

Capacity

Product
Shortening

Heating Format

Pressure

Shipping weight

Shipping Cube Dimensions

Listings

Electrical

Sides and back: 6 in. (152 mm)

5 sq. ft. (.46 m²)

12.5 lbs. (5.7 kg)

43 lbs. (19.5 kg)

Natural or liquid petroleum gas

(1) burner

(1) ½ in. connection

80,000 BTU/hr (23.4 kw)

Operating pressure: 12 psi. Safety valve setting: 14.5 psi.

363 lbs. (165 kg)

L x W x H: 44½ x 21¾ x 56 in. (113 x 55 x 142 cm)

CSA, UL EPH, CE

Voltage	Phase	Cycle/Hz	Watts	Amps	Wire
120	1	60	1150	10.0	2+G
190-208	1	50 or 60	1150	6.0	2+G
220-240	1	50 or 60	1150	6.0	2+G
230	1	50	1150	2.5	1NG

Optional power cord and plug can be supplied for 120V units, only. Plug type: 2-pole, 3-wire NEMA 5-15 P 

Specifications subject to change without notice.
For up-to-date product information, please visit
www.hennypenny.com.

Order from:

Manufactured by:

Henny Penny Corporation
PO Box 60
Eaton OH 45320 USA