



LEGEND™ Heavy-Duty Gas Steakhouse Infrared Broiler With Top Sear Plate

Item No. _____

Project _____

Quantity _____

C36SHB or C45SHB Model



Model C45SHB shown
with optional stainless steel sides and casters

SHORT/BID SPECIFICATION

Broiler shall be a Montague **Legend** Heavy-Duty, **Steakhouse** Broiler with Top Sear Plate [Specify Model]

- C36SHB 36" (914 mm) Wide
- C45SHB 45" (1143 mm) Wide

... a gas-fired, infrared heated unit with 42,000 BTU/hr cast iron burners with individual controls, heating ceramic radiants mounted below a 1/2" (13 mm) polished steel searing plate with 4" (102 mm) rear and side splash and above; a counter-balanced, height-adjustable, chrome-plated steel cooking grid that is drawer-mounted for easy pull-out access, with a full width grease deflector and large capacity front-mounted grease container; enclosed in an insulated cabinet with stainless steel front and mounted on 25" (635 mm) high stainless steel modular stand with bottom shelf; plus all the features listed and options/accessories checked:

TOP SEAR-PLATE FEATURES:

- 1/2" (13 mm) thick polished steel searing plate
- 4" (102 mm) high sides and rear splash
- 2-7/8" (73 mm) wide left-side grease trough
- Left-front mounted removable grease container, 4-3/4 quart capacity

BURNER/RADIANT SYSTEM FEATURES:

- 42,000 BTU/hr cast iron burners
- Ceramic radiants for uniform infrared heating
- Individual burner controls
- Standing pilot for automatic ignition

MODEL GUIDE

| ✓ | Model No. | Overall Width | Grids | Cooking Area | |
|---|-----------|---------------|-------|-----------------------------|------------------------------|
| | | | | Broiler | Griddle |
| | C36SHB | 36" (914 mm) | 2 | 27" x 27" (686 x 686 mm) | 33" x 28" (838 x 711 mm) |
| | C45SHB | 45" (1143 mm) | 3 | 35" x 27" (889 x 686 mm) | 42" x 28" (1067 x 711 mm) |

ROLL-OUT GRID FEATURES:

- Chrome plated steel grid sections: two on C36 & three on C45
- Counter-balanced grid assembly for easy height adjustment
- Infinite grid height adjustment from 2" to 5" (51 to 127 mm)
- Positive locking lift handle with cool ball-style grip
- Quiet, ball bearing mounted roll-out grid assembly
- Shielded horizontal grab-bar handle

STANDARD CONSTRUCTION FEATURES:

- Satin finish stainless steel front
- Broiler interior high-temp aluminized finish
- Other surfaces painted black with electrolytic zinc undercoating
- Full width grease deflector under rollout grid
- Extra-large capacity removable grease drawer [for broiler]
- 3/4" NPT rear gas manifold connection
- Stainless steel stand with 4" (102 mm) base and 21" (533 mm) tubular legs
- Height-adjustable bullet feet
- Stainless steel bottom shelf

STANDARD WARRANTY:

- Three Year, Parts & Labor

AGENCY APPROVALS

- NSF Listed
- CSA Design Certified to ANSI Z83.11*CSA 1.8



HDB-12 [Rev. 01/10]

LEGEND™ Heavy-Duty Gas Steakhouse Infrared Broiler with Top Sear Plate

Item No. _____

Project _____

Quantity _____

C36SHB or C45SHB Model

Dimensions in brackets are millimeters

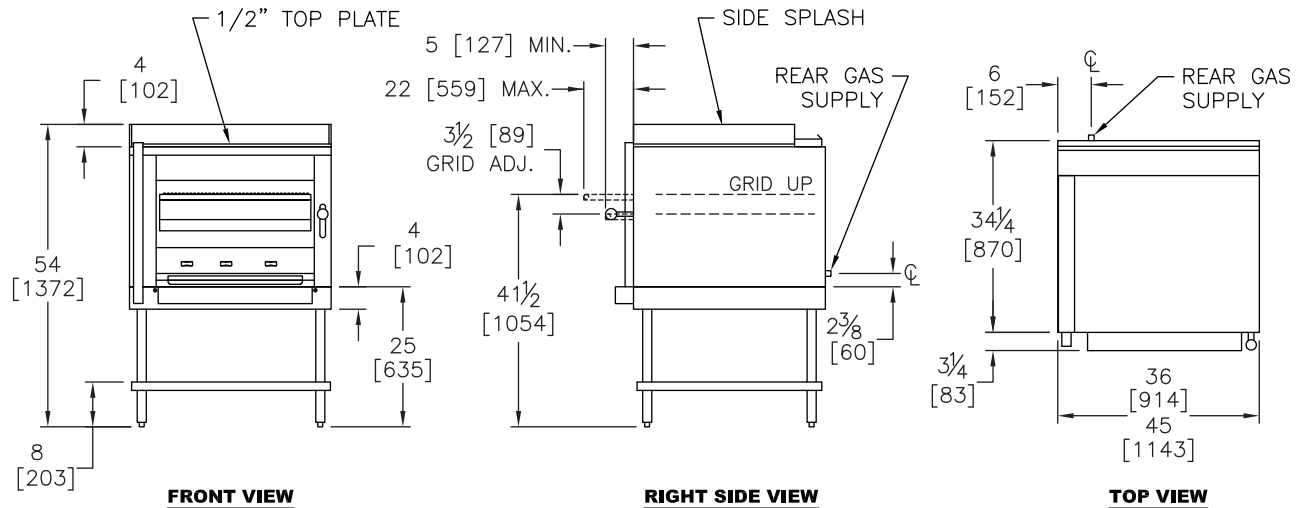

OPTIONS GUIDE:

Finish:

- Stainless steel full left side panel
- Stainless steel full right side panel
- Stainless steel back panel

General:

- Casters — set of four 5" (127 mm) casters
- Flex Connector Kit [3/4"] or [1"] NPT:
 - 3' (914 mm) long
 - 4' (1219 mm) long

Searing Plate:

- Side Mounted grease containers holds 2 quarts
- Grooved Top Plate - Consult factory

INSTALLATION REQUIREMENTS & SHIPPING INFORMATION

- Broilers must be installed in accordance with local codes or in their absence with the National Fuel Gas Code: ANSI Z223.1; Natural Fuel Gas Code: CAN/CGA-B149.1 or Propane Installation Code: CAN/CGA-B149.2, as applicable. Compliance with codes is the responsibility of the Owner and Installer.
- An adequate ventilation system is required. Refer to National Fire Protection Association Standard No. 96, "Standard for Ventilation and Fire Protection of Commercial Cooking Operations."
- This appliance is intended for commercial use by professionally trained personnel. NOT intended for Residential Use.
- Specify installation elevation: _____ if above 2000 feet (610 m).
- GAS INLET SIZE (All Models): 3/4" NPT left-rear inlet. A 3/4" NPT gas pressure regulator is provided and must be installed (by others) when unit is connected to gas supply.
- The incoming gas line pressure into the regulator should be 8"-14" w.c. for natural gas, and 12"-14" w.c. for propane gas.

| Minimum Clearances | Combustible Construction | Noncombustible Construction |
|-----------------------------------------------------------------------|--------------------------|-----------------------------|
| From Back Wall | 6" (152 mm) | 0" |
| Left & Right Side | 6" (152 mm) | 0" |
| With 21" (533 mm) legs, suitable for use on combustible floor. | | |

| Specify Type of Gas: | | <input type="checkbox"/> Natural | <input type="checkbox"/> Propane | Shipping Weight | Shipping Class | Cube (Crated) ft ³ /m ³ |
|--------------------------------------------|---------|----------------------------------|----------------------------------|------------------|----------------|-----------------------------------------------|
| Manifold Pressure: | | 6.0" WC | 10.0" WC | | | |
| Models: | Burners | BTU/hr (kW) | BTU/hr (kW) | | | |
| C36SHB | 2 | 84,000 (24.6) | 84,000 (24.6) | 483 lbs (219 kg) | 85 | 35/1 |
| C45SHB | 3 | 126,000 (36.9) | 126,000 (36.9) | 638 lbs (289 kg) | 85 | 47/1.3 |
| Uncrated entry clearance: 33-1/2" (851 mm) | | | | | | |

*Total, all burners



THE MONTAGUE COMPANY

1830 Stearman Avenue, Hayward, CA 94545

800 345-1830 • Fax: 510 785-3342

www.montaguecompany.com

Due to continuous product improvements, specifications are subject to change without notice.



HDB-12 [Rev. 01/10]