



# 300 SERIES RESTAURANT RANGE

6 Open Burners, 24" Wide Griddle, Double Oven

Standard Oven  
360DD-2G

### Standard Features

- Commercial gas range 60-1/2" wide with a 37" cooking height (including 6" high adjustable legs)
- 26,000 BTU NAT (20,000 BTU LP) Burners
- 6 clog-free, cast iron burners
- Removable cast iron, flush-top grates
- Single-piece drip tray under burners
- Smooth Polished griddle - 1/2" steel plate with raised sides 24-1/4" x 24-3/4" (right side only)
- Rigid single deck back shelf
- Stainless steel front and shelf
- Galvanized Sides
- One year Parts and Labor Warranty

### Standard Oven (D suffix)

- 32,000 BTU NAT (30,000 BTU LP)
- Large 26" wide x 26-1/2" deep oven - full sheet pans fit both ways
- Single rack per oven
- Equipped with a flame safety device
- Thermostat range from 250°-550°F (121°-288°C) with low setting
- Porcelain enamel bottom and door linings



(shown with optional casters)

Job #

### STANDARD CONSTRUCTION SPECIFICATIONS

**Exterior Finish:** Stainless steel front and shelf standard. Galvanized sides.

**Range Top:** 6 -26,000 BTU NAT (20,000 BTU LP) cast iron non-clogging burners. Removable Cast iron grates. Center-to-center measurements between burners not less than 12", side-to-side or front-to-back. Removable one piece drip tray provided under burners.

**Griddle:** Equipped with smooth Polished griddle -1/2" thick steel plate with high raised sides. 24-1/4" wide x 24-3/4" deep. Three 16,000 BTU (NAT or LP) Burners.

**Back Shelf:** Rigid, single deck stainless steel.

**Door:** Constructed with heavy duty hinges and unbreakable quadrants and heat resistant handle.

**Legs:** 6" black, adjustable

**Standard Oven (2) :** 32,000 BTU NAT (30,000 BTU LP) with thermostat range of 250°F to 550°F. Cavity sides, top and back -aluminized steel. Oven bottom and door lining porcelain enamel finish. Porcelain enamel oven interior, measuring 14" high x 26" wide x 26-1/2" deep. Two position rack guides with one removable rack. Factory installed pressure regulator.



**Models:**  360DD-2G

Dimensions -in (mm)

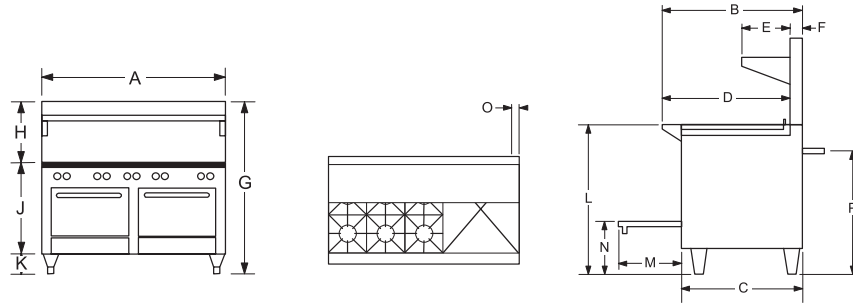

MODELS	EXTERIOR										COOK TOP L	DOOR OPENING M	OVEN BOTTOM N	3/4" GAS CONN.	
	WIDTH A	DEPTH B	C	D	E	F	G	H	J	K				O	P
360DD-2G	60.75" (1543)	34.00" (864)	29.75" (756)	31.00" (787)	12.00" (305)	2.75" (70)	59.50" (1511)	22.50" (572)	31.00" (787)	6.00" (152)	37.00" (940)	15.50" (394)	13.00" (330)	3.25" (83)	30.25" (768)

MODELS	BURNERS (BTU EACH NAT/LP)			OVEN INTERIOR			CRATE SIZE			CUBIC VOLUME	CRATED WEIGHT
	GRIDDLE	OPEN	OVEN	WIDTH	DEPTH	HEIGHT	WIDTH	DEPTH	HEIGHT		
360DD-2G	3@(16K/16K)	6@(26K/20K)	2@(32K/30K)	26.00" (660)	26.50" (673)	14.00" (356)	67.00" (1118)	45.50" (1170)	75.00" (1905)	132.3 cu. ft 3.75 cu.m.	860 lbs. 390.1kg

**UTILITY INFORMATION**

**Gas:**

- Total BTU: NAT: 268,000 BTU; LP: 228,000 BTU
- Required operating pressure:
  - Natural Gas 4" W.C.
  - Propane Gas 10" W.C.
- Pressure regulator is supplied with unit.
- Required supply line size to the regulator is 3/4" NPT.
- If using Flex-Hose, the I.D. should not be smaller than the I.D. of the manifold of the unit to which it is being connected
- Check local codes for fire and sanitary regulations.
- If the unit is connected directly to the outside flue, and A.G.A approved down draft diverter must be installed at the flue outlet of the oven

**MISCELLANEOUS**

- If using Flex-Hose, the I.D. should not be smaller than 3/4" and must comply with ANSI Z 21.69
- If casters are used with flex hose, a restraining device should be used to eliminate undue strain on the flex hose
- For installation on combustible floors (with 6" high legs) and adjacent to combustible walls, allow 6" clearance.
- Install under vented hood
- Check local codes for fire, installation and sanitary regulations.

**NOTICE:**

Southbend has a policy of continuous product research and improvement. We reserve the right to change specifications and product design without notice. Such revisions do not entitle the buyer to corresponding changes, improvements, additions or replacements for previously purchased equipment.

**OPTIONS AND ACCESSORIES**

- Casters-all swivel-front with locks
- Extra Oven Racks

**INTENDED FOR COMMERCIAL USE ONLY.  
NOT FOR HOUSEHOLD USE.**



1100 Old Honeycutt Road, Fuquay-Varina, NC 27526  
(919) 762-1000 www.southbendnc.com