



COUNTERLINE - GRIDDLE

Heavy Duty, Thermostatic, Gas

Standard Features

- Available in 24", 36", 48", 60" and 72" widths
- 30,000 BTU (NAT or LP) burner per 12"
- Electronic spark ignition (battery)
- Stainless steel front, vent and sides are standard, rear and bottom panels are aluminized steel.
- Reinforced, insulated double wall sides
- 1" thick polished rolled steel plate
- 5" high rear and side splash guards
- Flame failure safety device
- 3/4" rear gas connection and pressure regulator
- Protected flue opening
- "Insta-on" thermostatic controls for precise settings between 150°F and 400°F
- Imbedded load sensing thermostat
- Exclusive "NO COLD" Zone -Uniform heat distribution across surface
- Each burner equipped with runner tube
- 4" Spatula width front grease trough
- Optional 3" rear grease trough combined with 2-5/8" front grease trough, available on 36", 48" and 60". (does not reduce 24" griddle depth)
- Hidden grease drawers with large capacity
- Fully welded griddle plate with protected exhaust vent

HDG-24, HDG-36, HDG-48, HDG-60, HDG-72
HDG-36-RE, HDG-48-RE, HDG-60-RE



(Model HDG-36)

Job
Item#

STANDARD CONSTRUCTION SPECIFICATIONS

Exterior Finish: Front, sides and vent are constructed of #3 polished 430 and 304 stainless steel. Bottom and rear are aluminized steel. Sides are reinforced and fully insulated. 5" rear and side splash.

Griddle Plate: 24", 36", 48", 60", 72" wide unit with two 15,000 BTU (NAT or LP) burners every 12". Fully welded, 1" thick stainless steel griddle plate with side splash guards, and grease drawer.

Griddle Controls: Independent, "Insta-on" thermostatic controls with uniform temperature range of 150°F to 400°F.

Legs: Stainless steel 4" adjustable legs.

Gas Heat Control System: Each foot of griddle is heated by a "U" shaped burner. Each burner is controlled by a thermostatic control and is equipped with an independent pilot. For safety, each pilot has a flame failure device. A 3/4" rear gas connection is standard. Units over 48" wide are constructed of two bodies.



Standard Front Grease Trough Dimensions

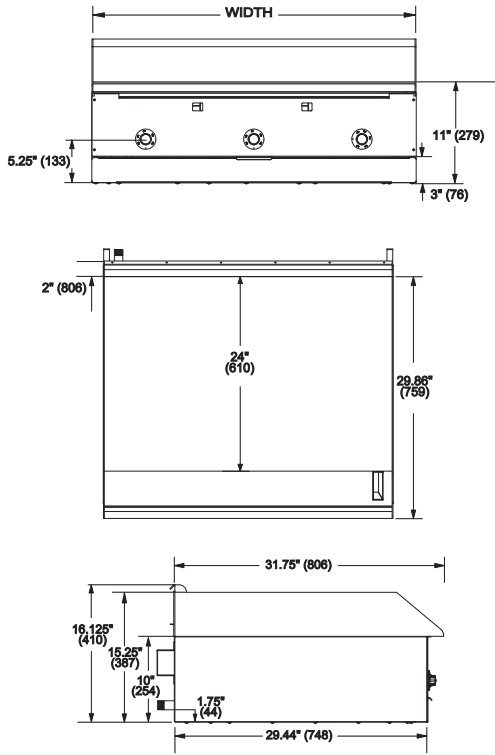

SHIPPING CRATE DIMENSIONS & WEIGHT					
MODEL	WIDTH	BURNERS @30,000 BTU	CRATED WIDTH	CRATED DEPTH	CRATED WEIGHT
HDG-24	24" (610)	2	31" (788)	39" (991)	305 lbs (159 kg)
HDG-36/ HDG-36-RE	36" (915)	3	55" (1398)	39" (991)	445 lbs (202 kg)
HDG-48/ HDG-48-RE	48" (1220)	4	55" (1398)	39" (991)	545 lbs (247 kg)
HDG-60/ HDG-60-RE	60" (1525)	5	67" (1703)	45.5" (1157)	705 lbs (320 kg)
HDG-72	72" (1830)	6	110" (2796)	45.5" (1157)	840 lbs (378 kg)

Optional Rear/Front Grease Trough Dimensions

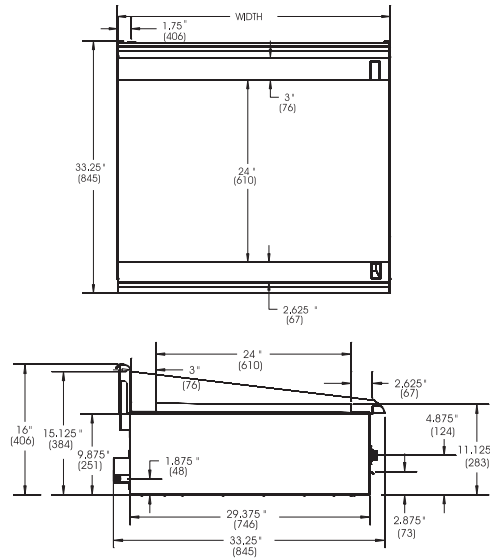

UTILITY INFORMATION

GAS: Each unit has a 3/4" rear gas connection with a male NPT connector. Minimum supply pressure is 7" W.C. for natural gas and 11" W.C. for propane. All units require a regulated gas supply, pressure regulator included. If using a flexible hose gas connection, the I.D. of the hose must not be smaller than the connector on the unit and must comply with ANSI Z21.69, providing an adequate means of restraint to prevent undue strain on the gas connection.

MODEL	GAS (BTU/HR)	
	NATURAL	PROPANE
HDG-24	60,000	60,000
HDG-36/ HDG36-RE	90,000	90,000
HDG-48/ HDG-48-RE	120,000	120,000
HDG-60/ HDG-60-RE	150,000	150,000
HDG-72	180,000	180,000

MISCELLANEOUS

- If casters are used with flex hose, a restraining device should be used to eliminate undue stain on the flex hose.
- Minimum clearance from noncombustible construction is zero. Minimum clearance from combustible construction is 10" on sides and 6" on rear.
- Install under vented hood.
- Check local codes for fire and sanitary regulations.

NOTICE: Southbend has a policy of continuous product research and improvement. We reserve the right to change specifications and product design without notice. Such revisions do not entitle the buyer to corresponding changes, improvements, additions or replacements for previously purchased equipment.

OPTIONS AND ACCESSORIES

- Stainless steel stand
- Casters for stand
- 2" high insulator base for mounting on refrigerated base
- Stainless steel plate shelf with or without cutting board
- Grooved griddle plates
- 3" Rear grease trough available on 36", 48" and 60" models
- Chrome plated griddle plates

**INTENDED FOR COMMERCIAL USE ONLY.
NOT FOR HOUSEHOLD USE.**



1100 Old Honeycutt Road, Fuquay-Varina, NC 27526
(919) 762-1000 www.southbendnc.com