

# Southern PRIDE

## SPECIFICATIONS MODEL SC-600-SM



### COOKING CAPACITIES FOR THE SC-600

Pork Butt (7 lb.)	96 pieces	672 lb. total
St. Louis Ribs (2.75 lb.)	112 pieces	308 lb. total
w/Optional Rib Racks	240 pieces	660 lb. total
Chicken (3 lb.)	200 pieces	600 lb. total
Brisket (12 lb.)	48 pieces	576 lb. total
Spare Ribs (3.5 lb.)	48 pieces	168 lb. total

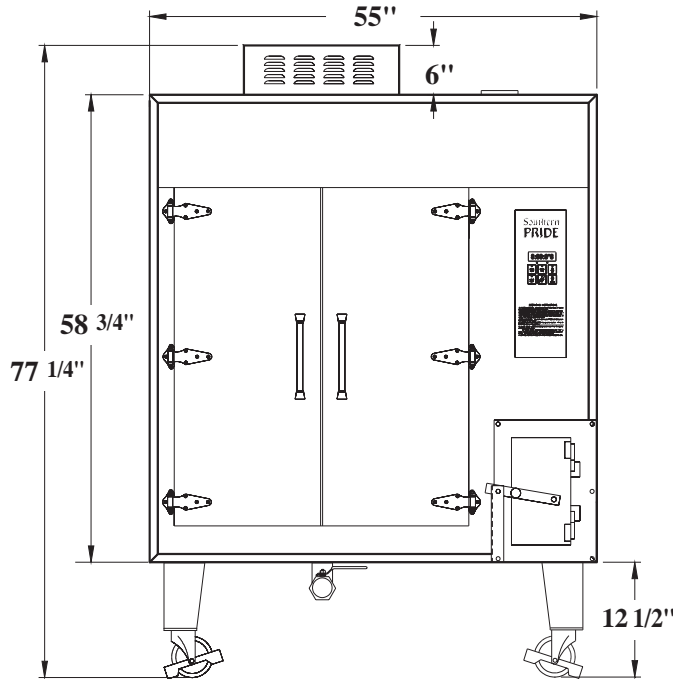

Front View

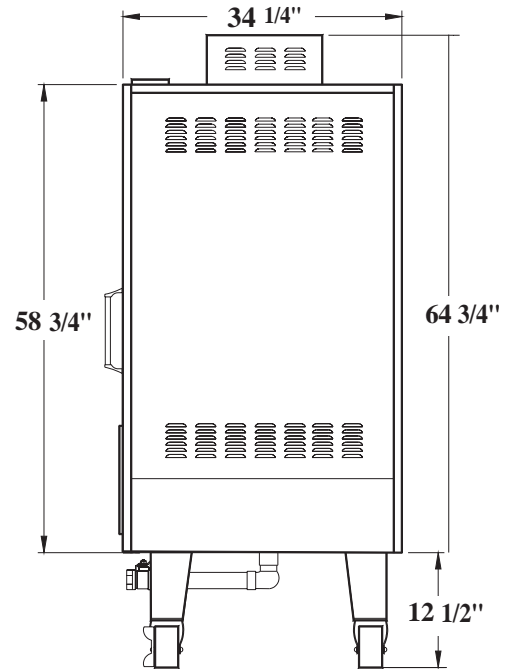

Side View

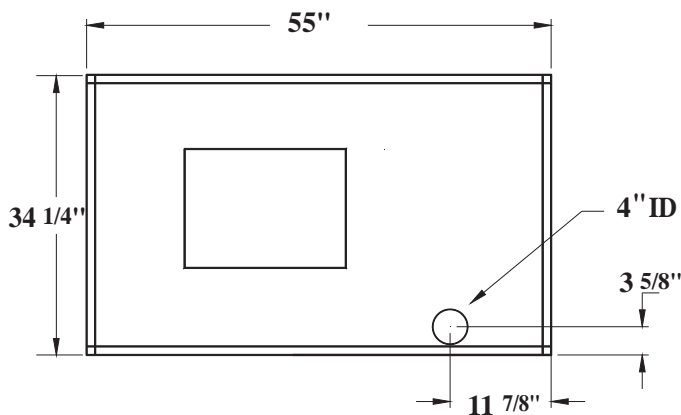

Top View

### SC-600-SM

**Electrical Requirements:** 120/208 or 120/240 volts AC, 60 hertz, 1 phase, 50 amp, 4 wire connection.

**Control:** Digital Roast and Hold

**Construction:** All 18 gauge Stainless Steel.

**Chipbox:** Uses small logs, chunks, or chips.

**Dimensions:** 77 1/4" tall, 55" wide, 34 1/4" deep

**Shell Dimensions:** 58 3/4" tall, 55" wide, 34 1/4" deep.

**Food Racks:** Eight food racks 33 1/2" x 31" 57.7 Sq.Ft. of Cooking Surface. 5" Rack Spacing.

**Air Circulation:** Low Velocity Convection Fan.

**Temperature Range:** 140-325 degrees F.

**Shipping Weight:** 1,000 lbs.

**Approvals:** UL, ULC, NSF   

**Venting:** Must be installed under a vent hood.

Contact local code officials and a commercial kitchen ventilation contractor prior to installation.

# Southern PRIDE

Southern Pride Distributing, L.L.C.

5003 Meadowland Pky - Marion, Illinois 62959-5892

www.southern-pride.com sales@sopride.com service@sopride.com parts@sopride.com

Sales: 800-851-8180

Service: 800-437-2679

Service Fax: 618-993-0378

Phone: 618-997-9348

Fax: 618-993-5960