

# The TEC® Searmaster® Infra-Red Broiler

TEC's Searmaster® Broiler Cooks Faster And Produces Better Tasting Food With Much Lower Gas Costs.

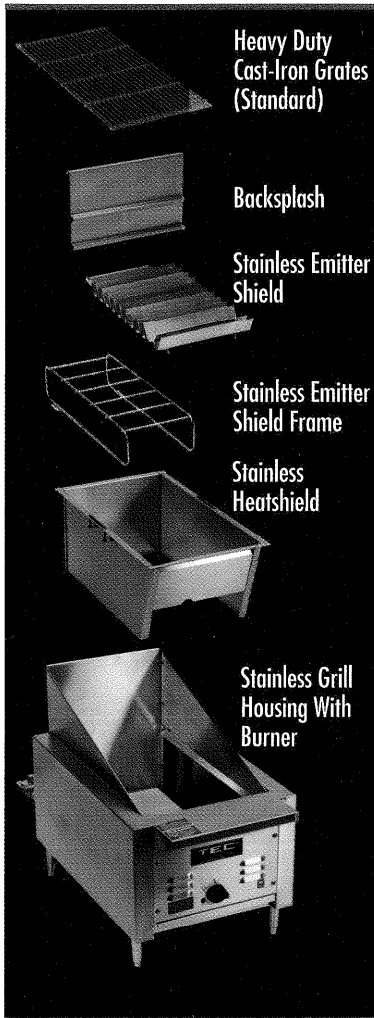

Powered by TEC's ceramic infra-red burners, the Searmaster® Infra-Red Broiler heats up 40% faster than competing models. And because it cooks with infra-red energy rather than hot air, the Searmaster® leaves food moist, tender and flavorful. Unlike the hot air produced by conventional broilers, the Searmaster's® radiant energy passes into the food without disturbing the moist boundary layer of molecules surrounding it. This energy causes molecules within food to speed up, generating friction, which causes food to cook without drying.

Juices that do fall to the emitter shields are vaporized, adding flavor back to the food with little or no flare-up. Contrast that with other grills where juices either flare-up into an inferno or fall onto dirty lava rocks or cool areas, creating a sticky, hard-to-clean mess.

TEC's infra-red cooking process provides extremely uniform heat. There are no cool spots. And multiple-burner units can achieve a full range of different heat settings.

Cleaning the Searmaster® is easy because of our heavy gauge, 304 stainless construction and removable emitter shields, heatshield, backsplash and front-loading grease tray.

No one makes a higher quality, better performing, easier-to-service broiler than the TEC Searmaster®.



## Features:

- Up to 47% more fuel-efficient than conventional broilers
- Uniform heat distribution
- Cooks 40% faster than conventional broilers
- Heats up in 17 minutes
- Easy-to-clean removable parts, simple to service
- Tough, durable stainless steel construction
- Natural or propane, 3/4" NPT gas manifold (regulator included)
- Equipped with bullet feet, which fit into stand frame tubing
- Heavy duty cast-iron grids can be used level or sloped

## Optional Accessories:

- Stainless steel diamond shaped or round bar cooking grids
- 12" and 24" steel frying griddle attachments
- Stainless steel rain cover
- Stands with bullet feet or casters, with or without undershelf

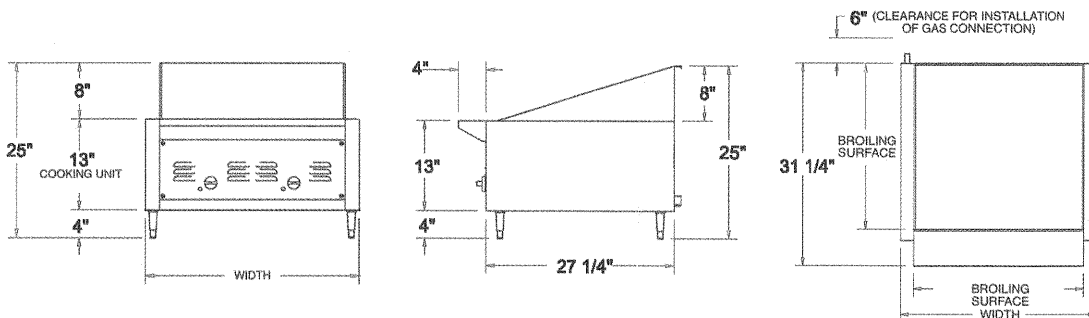

Model Number	Overall Width	Overall Depth	Broiling Surface		No. of Burners	Total BTU Input	Shipping Weight
			Width	Depth			
IR-2001-S	18 1/2 in.	31 1/4 in.	12 in.	24 in.	1	35,000	165 lbs.
IR-2002-S	30 1/2 in.	31 1/4 in.	24 in.	24 in.	2	70,000	227 lbs.
IR-2003-S	42 1/4 in.	31 1/4 in.	36 in.	24 in.	3	105,000	310 lbs.
IR-2004-S	54 1/8 in.	31 1/4 in.	48 in.	24 in.	4	140,000	395 lbs.